



Spoony 1.5 | Installation Guide



Evolutive
Solution



Load
Management



Secured



Cloud
connected



Intelligent
(automate)



Small



Simple



Wifi
Ethernet

Smart Grid deployment lacks a flexible way to gather data and act onto network.

Spoony, Cloud Device, is the solution.

Directly installed within an electric panel (format DIN 3/2), captures energy consumption data, analyzes and transmits it through the Cloud.

This programmable device can answer to any request regarding energy management system.

Version du document

Date	Version	Auteur	
18/11/2015	1.0	Nicolas Leday	Première publication

Summary

SAFETY INSTRUCTIONS	3
PRODUCT VERSION	3
PRODUCT PACKAGE CONTENT	4
OPTIONAL ACCESSORIES	4
HANDLING	4
PRODUCT INSPECTION	4
PRODUCT PINOUT & CONNECTIONS	5
GLOBAL VIEW	5
MAIN TERMINAL BLOCKS PINOUT	6
SECONDARY TERMINAL BLOCKS PINOUT	7
PRODUCT WIRING	8
POWER SUPPLY	8
VOLTAGE & CURRENT MEASUREMENT INPUTS	8
3-PHASE + NEUTRAL ELECTRICAL NETWORK (DELTA)	9
1 PHASE ELECTRICAL NETWORK	10

Safety instructions



This product must be installed, configured, and put into service by qualified personnel only. Usual electrical security rules apply and must be followed. In case of incorrect installation or usage, damages to the user or the product can occur.



This product must only be manipulated when no power is present. Risk of electrical shock exists if the product is misused.



This product must be installed, configured and used according to the related documentation. Any use not described in the related documentation must be considered unsafe. If the product is not used according to the cases described in the related documentation, no warranty is applicable.



To avoid product overheating, only use in a well ventilated area.



Product disassembly and fixing can only be realized by authorized and qualified personnel. In case of doubt regarding the product functioning, please contact DotVision. Incorrect use can damage the product.

Product version

This manual concern product version 1.5 ONLY. Any other version of the product must following related documentation.

Product package content

Following accessories are provided with Spoony :

- Micro SD card
- Micro SD / SD adapter

Optional accessories

Following accessories are available as options in order to extend product fonctionnalities. Please contact DotVision for further informations

- Split-core current transformers
- Rogowski coil current sensors
- Wifi extension card

Notes: - Split-core & Rogowski coils can only be installed on matching version of Spoony. Do not install rogowski Coils on a product sold for compatibility with Current transformers.

- Current transformers or Rogowski coils are needed for full product functionality. Please ask DotVision for references fitting your target application.

Handling

The product must be carried in its original packaging only. The product package is made to protect the product. Remove the product from its packaging only when on installation site. In order to protect the product from any damage caused by moisture, unwrap it and wait until all humidity has evaporated before putting into service.

Product inspection

Please inspect each part of the product before installation and check that all parts are presents. Keep product package in case you must carry it. If the product present visible damages or defect, or if some parts are missing, do not install the product and contact DotVision.

Product Pinout & Connections

Global view

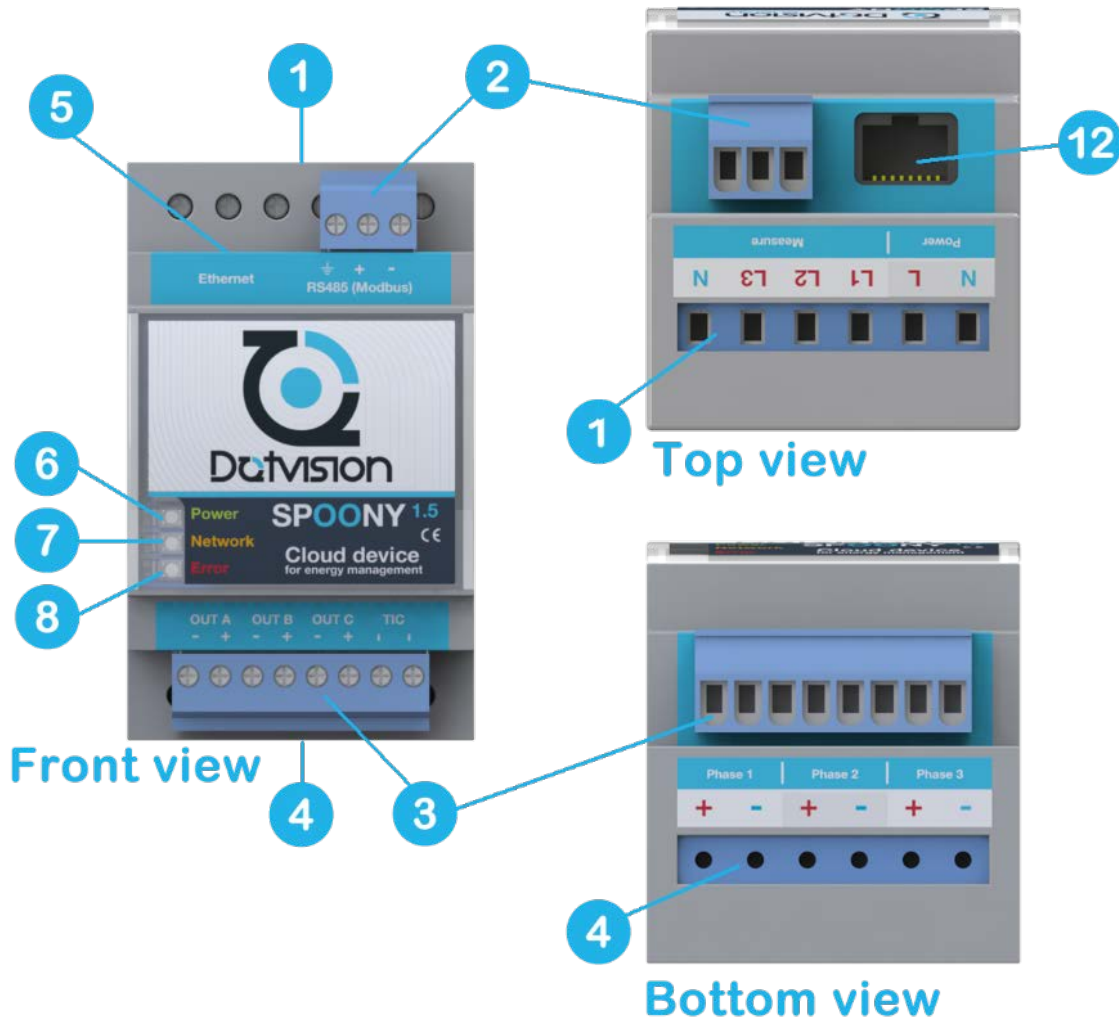

- (1) Power & Voltage measurement terminal block
- (2) RS485 secondary terminal block (removable)
- (3) Outputs & TIC secondary terminal block (removable)
- (4) Current measurement terminal block

- (5) RJ45 Ethernet connector
- (6) LED 1 (Green)
- (7) LED 2 (Orange)
- (8) LED 3 (Red)

Main terminal blocks pinout



Note : Secondary terminal blocks have been removed for better visibility

Power & Voltage measurement terminal block (Top)

- (N) Supply Neutral
- (L) Supply Phase
- (N') Measure Neutral
- (L1) Measure Phase 1
- (L2) Measure Phase 2
- (L3) Measure Phase 3

Current measurement terminal block (Bottom)

- (CT1+) Phase 1 Current Transformer, Positive side
- (CT1-) Phase 1 Current transformer, Negative side
- (CT2+) Phase 2 Current Transformer, Positive side
- (CT2-) Phase 2 Current transformer, Negative side
- (CT3+) Phase 3 Current Transformer, Positive side
- (CT3-) Phase 3 Current transformer, Negative side

Secondary terminal blocks pinout



RS485 terminal block (Top)

(G) Ground

(+) TX / RX +

(-) TX / RX -

Outputs & TIC terminal block (Bottom)

(OUTA+) Output A, Positive side

(OUTA-) Output A, Negative side

(OUTB+) Output B, Positive side

(OUTB-) Output B, Negative side

(OUTC+) Output C, Positive side

(OUTC-) Output C, Negative side

(T1) TIC input pole 1

(T2) TIC input pole 2

Product Wiring

Power supply



Product must be powered through poles **N** & **L** of the Power & Voltage measurement terminal block.

Power supply must satisfy to the following specifications :

Min voltage : 80V (AC or DC)
Max voltage : 240V (AC or DC)

This input is typically connected to the Neutral & Phase on most installations, as shown onto the figure.

Product powered from Mains

Voltage & Current measurement inputs

The product must be connected to mains through poles **L1**, **L2**, **L3** & **N'** to allow for voltage measurement.

Current transformers or Rogowski coils must also be connected to poles **I1+**, **I1-**, **I2+**, **I2-**, **I3+**, **I3-** to allow for current measurement.

Product wiring depends on usage and electrical network topology.

Following schematics presents possible products wiring. Please feel free to contact DotVision in case you have special needs not mentioned in the followings schematics.

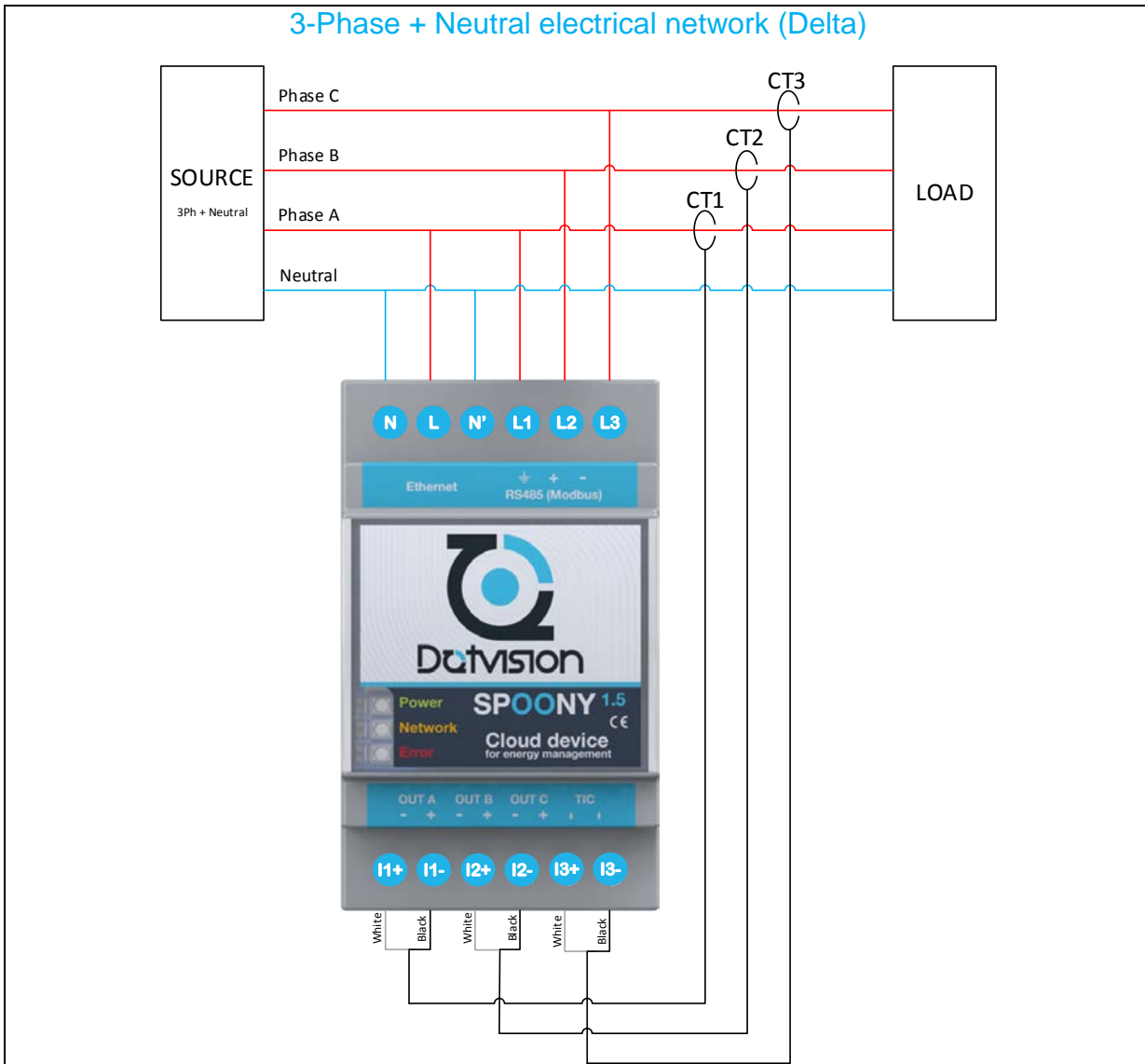

Notes: Schematics present current transformers but same schematic apply when using Rogowski Coils.

⚠️ Current transformers wire colors apply only to current transformers provided by DotVision.

Max voltage:

$$80V_{rms} < V_{NA} < 240V_{rms}$$

$$V_{NB}, V_{NC} < 600V_{rms}$$

V_{NA} , V_{NB} & V_{NC} respectively refers to voltages between :

- Phase A & Neutral
- Phase B & Neutral
- Phase C & Neutral

⚠️ Rogowski coil version of the product is provided with Screw terminal blocks for rogowski coils cabling and must be wired accordingly.

⚠️ Current transformer version is provided with Push-On terminal blocks. Use a screw driver to press onto the terminal blocks and insert wire. Do not try to screw these terminal blocks.

⚠️ Rogowski coil version is calibrated by DotVision to ensure correct measurement. Please use intended Rogowski coils on each input. All Rogowski coils supplied by DotVision have a label indicating attached product serial number as well as target product input (1, 2 or 3). Please install exclusively product with matching Rogowski coils wired to matching inputs to obtain optimal measurement precision.

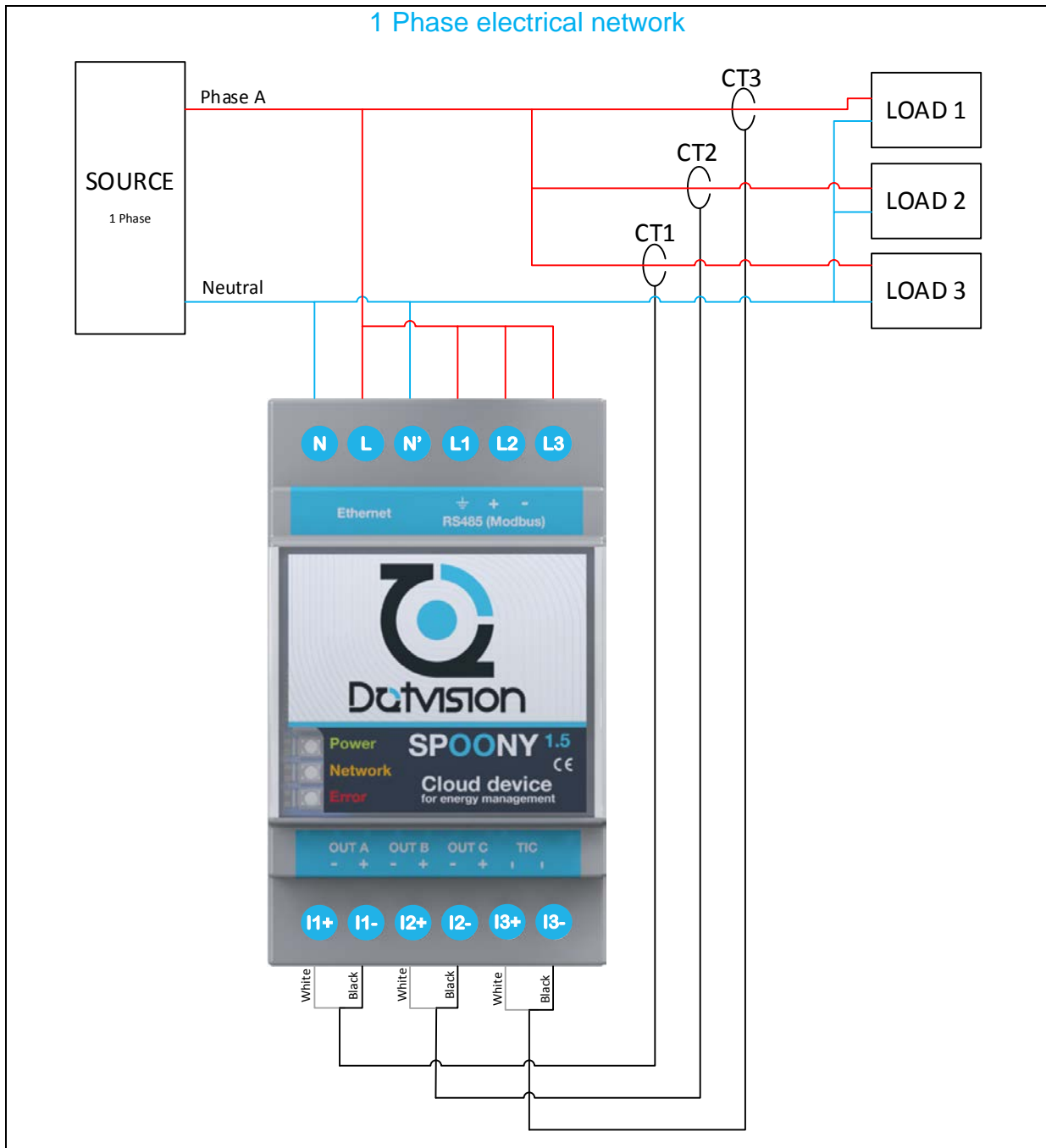

When used on single-phase electrical network, Spoony can be used to measure 3 different appliances. This usage is specially adapted for use on home electrical networks.

Notes: Schematics present current transformers but same schematic apply when using Rogowski Coils.

Current transformers wire colors apply only to current transformers provided by DotVision.

⚠ Max voltage:

$$80V_{rms} < V_{NA} < 240V_{rms}$$

$$V_{NB}, V_{NC} < 600V_{rms}$$

V_{NA} , V_{NB} & V_{NC} respectively refers to voltages between :

- Phase A & Neutral
- Phase B & Neutral
- Phase C & Neutral

⚠ Rogowski coil version of the product is provided with Screw terminal blocks for rogowski coils cabling and must be wired accordingly.

⚠ Current transformer version is provided with Push-On terminal blocks. Use a screw driver to press onto the terminal blocks and insert wire. Do not try to screw these terminal blocks.

⚠ Rogowski coil version is calibrated by DotVision to ensure correct measurement. Please use intended Rogowski coils on each input. All Rogowski coils supplied by DotVision have a label indicating attached product serial number as well as target product input (1, 2 or 3). Please install exclusively product with matching Rogowski coils wired to matching inputs to obtain optimal measurement precision.